



Refractory Solutions For High-Temperature Industries

Professional / Effective / Reliable



Iron & Steel



Non-ferrous



Glass



Cement & Lime

Zhengzhou Kerui (Group) Refractory Co., Ltd.

Contents

Serving the Global High-temperature Industry

- 4** Welcome to Kerui
- 5** Kerui Production View
- 7** Kerui Certificates
- 8** Kerui R&D Center
- 9** Kerui Partners
- 10** Refractory Bricks
 - 11. High Alumina Brick
 - 12. Fireclay Brick
 - 13. Corundum Brick
 - 14. Mullite Brick
 - 15. Sillimanite Brick
 - 16. Chrome Corundum Brick
 - 17. AZS Brick
 - 18. Andalusite Brick
 - 19. Magnesite Brick
 - 20. Magnesite Chrome Brick
 - 21. Magnesite Carbon Brick
 - 22. Magnesite Alumina Spinel Brick
 - 23. Magnesite Iron Spinel Brick
 - 24. Carbon Brick
 - 25. Silica Brick
 - 26. Silicon Carbide Brick
 - 27. Chromic Oxide Brick
 - 28. Alumina Silicon Carbide Brick
 - 29. Silicon Nitride Bonded Silicon Carbide Brick
 - 30. Acid Proof Brick
 - 31. Refractory Balls
- 32** Insulation Brick
 - 33. High Alumina Insulation Brick
 - 34. Fire Clay Insulation Brick
 - 35. Mullite Brick
 - 37. Alumina Bubble Brick
 - 38. Silica Insulation Brick
- 39** Monolithic Refractory
 - 40. Calcium Aluminate Cement
 - 42. Ca50 Fused Cement
 - 43. High Alumina Castable
 - 44. Alumina Magnesium Refractory Castable
 - 45. Mullite Castable
 - 46. Corundum Castable
 - 47. Silicon Carbide Castable
 - 48. Lightweight Insulating Castable
 - 49. Wear-resistant Castable

Contents

Serving the Global High-temperature Industry

50 Ceramic Fiber Products

- 51. Ceramic Fiber Blanket
- 52. Ceramic Fiber Board
- 53. Ceramic Fiber Cloth
- 54. Ceramic Fiber Paper
- 55. Ceramic Fiber Rope
- 56. Ceramic Fiber Cotton
- 57. Ceramic Fiber Module
- 58. Calcium Silicate Board
- 59. Alumina Ceramic
- 61. Honeycomb Ceramic Regenerator
- 62. Ceramic Saddles & Supper Saddles

65 RBSiC / SiSiC Silicon Carbide Kiln Shelves Products

- 66. OBSiC Silicon Carbide Plates
- 68. Silicon Carbide Products
 - SiSiC (RBSiC) Rollers
 - SiSiC Cross BEAMS
 - SiSiC Crucible Sagger
 - SiSiC Radiation Pipe
 - SiSiC Cooling Air Pipe
 - Reaction Sintered Silicon Carbide Paddles
 - SiSiC (RBSiC) Burner Nozzles
 - Desulphurization Spray Nozzle
 - Vortex hollow cone spray nozzle
 - Spiral spray nozzle
 - Silicon Carbide Graphite Crucible
- 73. (RSiC) Kiln Furniture
- 74. Si₃N₄ bonded SiC Kiln Furniture
- 75. Sintered Silicon Carbide
- 76. Cordierit-Mullite Kiln Shelves
 - Plain Battss
 - Extruded Battss
 - Grooved Battss
 - Extruded Supports
 - Base / Shape Supports
 - Cubic Supports / Splicers

Welcome to Kerui

Expert of Refractory Solutions

Founded in 2004, Kerui Refractory is an international high-tech enterprise integrating R&D and innovation, manufacturing, solutions and service of high-performance refractory products.

Kerui attached great importance on R&D. In the past decades, we've obtained one invention patent certificate and more than 20 utility model patent certificates. Kerui insists on technological innovation to provide customers with better products.

KERUI main products include refractory bricks, insulating bricks, ceramic fiber products, unshaped refractory materials, etc. All the products are widely applied in high-temperature industries worldwide, such as iron-steel, aluminum, power, glass, boiler, non-ferrous, cement industry, etc., contributing to the development of global high-temperature industry.



Kerui Production View

Serving the Global High-temperature Industry

Raw Material Workshop

It covers an area of more than 3,000 square meters. There are complete categories and sufficient reserves to ensure the supply of raw materials required for stable production.



Batching Workshop

There is a fully automatic batching system. Through coarse, medium and fine crusher screening equipment, as well as powerful mixing equipment, the computer automatically controls the batching. Therefore, the uniformity and stability of the product is fundamentally ensured.



Forming Workshop

There are 20 sets of new CNC presses of 400-1000 tons. These machines have strong power and accurate dimensions, which can effectively improve the strength of products and ensure stable quality. Kerui adopts steel molds and special-shaped bricks can be customized in multiple sizes.



Kerui Production View

Serving the Global High-temperature Industry

Sintering Workshop

Kerui has possessed two 168 meter tunnel kilns, two high-temperature shuttle kilns, etc., which can ensure the annual production capacity of 150000t. We also have strong customization ability. The special-shaped and customized products have met different customers' requirement and won unanimous praise from customers.



Warehousing Workshop

After the finished product passes the quality inspection, it can be stored in the warehouse after being bundled and packaged with wooden pallets, three-layer plastic film, and steel straps. Kerui has a 5,000-square-meter modern warehousing workshop. This workshop integrates warehousing, packaging and shipping. It ensures the products to be delivered on schedule.



Digital Management

Kerui adopts a digital production centralized control center to strictly control the production process. From the selection and proportion of raw materials selection to the molding and sintering of refractory materials, Kerui has established a complete corporate product quality traceability system and production management system.



Kerui Certificates

Qualified by Certificates

Kerui Refractory has a number of international certifications, also have many domestic certificates, the quality is very guaranteed, and they have been unanimously recognized by customers at home and abroad.



Kerui R&D Center

Always Conducts Strict Quality Control

Focus on refractory industry for 20 years, Kerui Refractory stands out because of superior refractory products. Kerui established engineering technology center and professional physical and chemical analysis laboratory to control the quality.



Kerui Partners

All Over The World

KERUI has become the first choice of worldwide customers across 5 continents, including Asia, Europe, America, Africa, Oceania.

We serve the high-temperature industries all over the world, including iron and steel, aluminum, glass, cement, etc. We have a team of highly qualified and experienced application engineers, providing the " **TOTAL REFRACTORY SOLUTIONS** " to customers.





Refractory Bricks

Serving the Global High-temperature Industry

High Alumina Brick



High Working
Temperature



Good Thermal
Stability



Strong Slag
Resistance



Good Erosion and
Corrosion Resistance

Application:

High alumina brick is used for lining steel-making electric furnaces, glass melting furnaces, and cement rotary furnaces.

Technical Data:

Item		LZ-80	LZ-75	LZ-70	LZ-65	LZ-60	LZ-55	LZ-48
Al ₂ O ₃ , %	≥	80	75	70	65	60	55	48
Apparent Porosity, %	≤	21	24	24	24	26	22	22
Cold Crushing Strength, MPa	≥	70	60	55	50	45	45	40
0.2MPa Refractoriness Under Load, °C	≥	1530	1520	1510	1500	1430	1450	1420
Permanent Linear Change, %		1500°C*2h -0.4~0.2			1450°C*2h -0.4~0.1			

Fireclay Brick



High Working
Temperature



Proper Thermal
Stability



Proper Acid
Resistance



Good Thermal
Shock Resistance

Application:

Clay bricks are divided by use and are mainly divided into clay refractory bricks for blast furnaces, clay refractory bricks for hot blast furnaces, and large clay refractory bricks for coke ovens and glass kilns.

Technical Data:

Item		PN-42	PN-40	PN-35	PN-30
Al ₂ O ₃ , %	≥	42	40	35	30
Fe ₂ O ₃ , %	≤	2.0	/	/	/
Apparent Porosity, %	≤	20	24	26	23
Cold Crushing Strength, MPa	≥	45	35	30	30
0.2MPa Refractoriness Under Load, °C	≥	1400	1350	1320	1300
Permanent Linear Change, %		1400°C*2h -0.4~0.1	1350°C*2h -0.4~0.1	1300°C*2h -0.4~0.1	1300°C*2h -0.4~0.1



High Working
Temperature



Good Thermal
Stability



High Cold
Crushing Strength



Strong Resistance on
Chemical Corrosion

Application:

Corundum brick is mainly used in iron-making blast furnaces and hot blast furnaces, steel-making furnace external refining furnaces, sliding water heaters, glass melting furnaces and petrochemical industrial furnaces.

Technical Data:

Item		GYZ-99	GYZ-90	GYZ-80
Al ₂ O ₃ , %	≥	99	90	80
SiO ₂ , %	≤	0.2	8	18
Fe ₂ O ₃ , %	≤	0.2	0.2	0.3
Bulk Density, g/cm ³	≥	3.2	3	2.8
Apparent Porosity, %	≤	19	18	18
Cold Crushing Strength, MPa	≥	100	100	100
0.2MPa Refractoriness Underload, °C	≥	1700	1700	1700

Mullite Brick



High Working
Temperature



Excellent Thermal
Shock Resistance



Great Wear
Resistance



Good Erosion and
Corrosion Resistance

Application:

Mullite brick is mainly used in hot blast furnace tops, blast furnace shafts and bottoms, glass melting furnace regenerators, ceramic sintering kilns, dead-end furnace linings in petroleum cracking systems, etc.

Technical Data:

Item		MLS-75	MLS-70
Al ₂ O ₃ , %	≥	75	70
SiO ₂ , %	≤	23	25
Fe ₂ O ₃ , %	≤	0.4	0.4
Bulk Density, g/cm ³	≥	2.7	2.6
Apparent Porosity, %	≤	18	18
Cold Crushing Strength, MPa	≥	100	100
0.2MPa Refractoriness Under Load, °C	≥	1680	1680

Sillimanite Brick



High Working
Temperature



Good Thermal
Stability



Great Wear
Resistance



Excellent Thermal
Shock Resistance

Application:

Sillimanite refractory materials are widely used in glass kilns, blast furnaces, ceramics, etc. in metallurgy, chemical industry, building materials and other industries.

Technical Data:

Item		GXS-65	GXS-60
Al ₂ O ₃ , %	≥	65	60
SiO ₂ , %	≤	32	37
Fe ₂ O ₃ , %	≤	0.5	1
Bulk Density, g/cm ³	≥	2.5	2.3
Apparent Porosity, %	≤	18	19
Cold Crushing Strength, Mpa	≥	80	80
0.2MPa Refractoriness Underload, °C	≥	1650	1600

Chrome Corundum Brick



High Working
Temperature



Good Thermal
Shock Resistance



Great Wear
Resistance



Good Erosion and
Corrosion Resistance

Application:

Chrome corundum brick can be used as glass kiln lining, brushed glass flow hole cover brick and used in molten iron pretreatment device, garbage incinerator, coal water slurry pressurized gasification furnace backing, etc.

Technical Data:

Item/Grade		GGZ-30	GGZ-20	GGZ-12	GGZ-5
Cr ₂ O ₃ , %	≥	30	20	12	5
Fe ₂ O ₃ , %	≤	0.3	0.3	0.3	0.3
Al ₂ O ₃ , %	≥	68	76	80	85
Apparent Porosity, %	≤	18	18	18	18
Bulk Density, g/cm ³	≥	3.5	3.4	3.2	3.1
Cold Crushing Strength,MPa	≥	100	100	100	100



High Working Temperature



Good Thermal Shock Resistance



Great Wear Resistance



Excellent Erosion and Corrosion Resistance

Application:

AZS brick is used as refractory materials for high temperature and erosion resistant kilns such as glass industrial pool kilns, glass electric kilns, slides in the steel industry, and kilns in the soda ash industry.

Technical Data:

Item	KR-AZS41	KR-AZS36	KR-AZS33
SiO ₂ , %	12	13	15
Al ₂ O ₃ , %	The Remainder	The Remainder	The Remainder
ZrO ₂ , %	41	36.5	33.5
Fe ₂ O ₃ +TiO ₂ +CaO+MgO+Na ₂ O+K ₂ O, %	≤2.0	≤2.0	≤2.0
Bulk Density, g/cm ³	4.05	3.9	3.8
Apparent Porosity, %	0.6	0.8	0.7
Initial Precipitation Temperature of Vitreous Phase, °C	1400	1400	1400
Vitreous Phase Exudation, % (1500°C×4h)	1.5	2.3	2.0
Anti-molten Glass Erosion Speed Under Static Condition, mm/24h (1500°C × 36h, ordinary soda lime glass)	1.2	1.3	1.4
Bubble Release Rate, % (1300°C X 10h, ordinary soda lime glass)	0.6	1.0	1.2

Andalusite Brick



High Working
Temperature



Good Thermal
Shock Resistance



Good Thermal
Stability



Good Erosion and
Corrosion Resistance

Application:

Andalusite bricks with excellent performance can fully meet the requirements for use in different parts of blast furnaces and hot blast stoves and in different working environments.

Technical Data:

Item		RH-155	RH-150	RH-145	RH-140	RH-135	RH-130
Al ₂ O ₃ , %	≥	69	65	61	57	53	49
Fe ₂ O ₃ , %	≤	1	1	1.2	1.2	1.5	1.5
TiO ₂ , %	≤	0.5	0.5	0.5	0.6	0.6	0.6
Apparent Porosity, %	≤	20	20	20	20	20	20
Bulk Density, g/cm ³		2.55~2.70	2.50~2.65	2.45~2.60	2.40~2.55	2.35~2.50	2.30~2.45
Cold Crushing Strength, MPa		55	55	50	50	40	40
0.2MPa Refractoriness Under Load, °C	≥	1700	1700	1650	1600	1520	1450
Permanent Line Change, %		1500°C×2h			1450°C×2h		

Magnesia Brick



High Working
Temperature



Strong Resistance
to Alkaline Slag



High Thermal
Conductivity



High Softening
Temperature Under Load

Application:

Magnesia brick is mainly used in alkaline open-hearth furnaces, electric furnace bottoms and furnace walls for steelmaking.

Technical Data:

Item		M-98	M-97A	M-97B	M-95	M-91
MgO, %	≥	97.5	97.0	96.5	95.0	91.0
SiO ₂ , %	≤	1.00	1.20	1.50	2.00	/
CaO, %	≤	/	/	/	2.00	3.00
Apparent Porosity, %	≤	16	16	18	16	18
Bulk Density, g/cm ³	≥	3.00	3.00		2.95	2.90
Cold Crushing Strength, MPa	≥	60	60		60	60
0.2MPa Refractoriness Under Load, °C	≥	1700	1700		1650	1560
Permanent Linear Change, %		1650°C*2h -0.2-0	1650°C*2h -0.2-0		1600°C*2h -0.3-0	1600°C*2h -0.5-0

Magnesia Chrome Brick

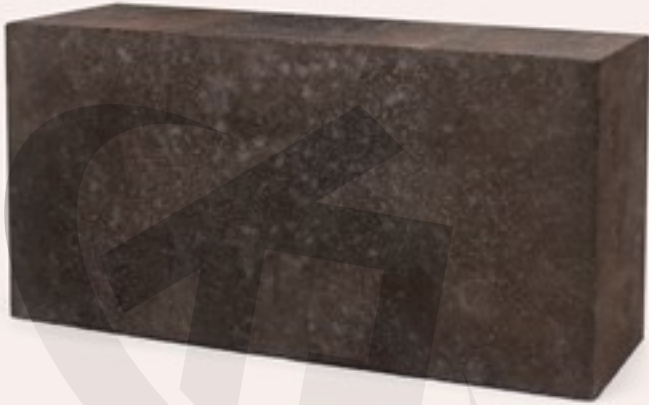

High Working
Temperature



High Temperature
Strength



Strong Resistance to Alkaline
Slag Corrosion to Alkali Erosion



Excellent Thermal
Stability

Application:

Magnesia chrome brick is mainly used in the metallurgical industry, such as constructing open-hearth furnace tops, electric furnace tops, external refining furnaces and various alkali-resistant non-ferrous metal smelting furnaces.

Technical Data:

Item		MGe-16A	MGe-16B	MGe-12A	MGe-12B	MGe-8A	MGe-8B
MgO, %	≥	50	45	60	55	65	60
Cr ₂ O ₃ , %	≥	16	16	12	12	8	8
Apparent Porosity, %	≤	19	22	19	21	19	21
Cold Crushing Strength, MPa	≥	35	25	35	30	35	30
0.2MPa Refractoriness Under Load, °C	≥	1650	1550	1650	1550	1650	1530

Magnesia Carbon Brick



High Working
Temperature



Good Thermal
Shock Resistance



Strong Slag
Resistance



Low Creep Rate in
High Temperature

Application:

Magnesia carbon bricks are mainly used in the lining of converters, AC electric arc furnaces, DC electric arc furnaces, and slag lines of ladles in the steelmaking industry.

Technical Data:

Item		MT-8A	MT-8B	MT-10A	MT-10B	MT-12A	MT-12B	MT-14A	MT-14B	MT-16A	MT-16B	MT-18A	MT-18B
MgO, %	≥	82	81	80	79	78	77	76	74	74	72	72	70
C, %	≥	8	8	10	10	12	12	14	14	16	16	18	18
Apparent Porosity, %	≤	4.5	5.0	4.0	4.5	4.0	4.0	3.5	3.5	3.5	3.5	3.0	3.5
Bulk Density, g/cm ³	≥	3.05	3.00	3.02	2.97	2.97	2.94	2.95	2.90	2.92	2.87	2.89	2.84
Cold Crushing Strength, MPa	≥	45	45	40	40	40	35	38	35	35	35	35	30

Magnesia Alumina Spinel Brick



Good Thermal Stability



Strong Resistance to Erosion



Lower Thermal Conductivity



Good Resistance to Peeling

Applications:

Mainly used in non-ferrous metal smelting furnaces, such as steel nickel furnaces and aluminum smelting furnace linings, electric furnace covers, steel drum linings, steel refining vacuum treatment equipment linings, high-temperature belt linings in cement calcination kilns, steel storage chambers in open hearth furnaces, and lattice bricks in glass furnace heating chambers.

Technical Data:

Item		Index
MgO ,%	≥	80
Al ₂ O ₃ ,%	≥	10
Apparent Porosity ,%	≤	17
Bulk Density ,g/cm ³	≥	2.9
Cold Crushing Strength ,Mpa	≥	50
High-temperature Bending Strength (1350°C*0.5h), MPa	≥	3.5
Thermal Shock Resistances (1100°C , Water Cooling), Cycle	≥	12

Magnesia Iron Spinel Brick



High Working
Temperature



Good Thermal
Shock Resistance



High Compressive
Strength



Strong Resistance to
Erosion and Permeability

Application:

Magnesia iron spinel brick is an ideal chromium free alkaline refractory material for cement rotary kiln firing.

Technical Data:

Item		MFe-85A	MFe-85B
MgO ,%	≥	85	85
Al ₂ O ₃ ,%	≥	3-5	3-5
Fe ₂ O ₃ ,%	≥	4-6	4-6
Bulk Density ,g/cm ³	≥	2.95	2.90
Cold Crushing Strength ,Mpa	≥	55	50
0.2MPa Refractoriness Under Load,°C	≥	1650	1600



Extremely High Refractoriness.



High Refractoriness Under Load



Strong Slag Resistance



High Compressive Strength

Application:

Carbon bricks are mainly used for building the bottom and belly of blast furnaces, for the lining of aluminum electrolytic cells, ferroalloy industrial furnaces, and for smelting non-ferrous metal linings.

Technical Data:

Item/Grade		Index
C, %	≥	90
Bulk Density, g/cm ³	≥	1.6
Cold Crushing Strength, Mpa	≥	35
Apparent Porosity, %	≤	16
Ash Content, %	≤	8



High Working
Temperature



Good Thermal
Stability



Good Resistance to
Acid Slag Corrosion



High Refractoriness
Under Load

Application:

Silica brick is mainly used as structural materials for coke ovens, glass furnaces, acid steelmaking furnaces and other thermal equipment.

Technical Data:

Item/Grade		GZ-94	GZ-95	GZ-96
SiO ₂ , %	≥	94	95	96
Fe ₂ O ₃ , %	≤	1.4	1.2	1.0
Apparent Porosity, %	≤	22	22	22
Bulk Density, g/cm ³	≤	2.35	2.35	2.34
Cold Crushing Strength, MPa	≥	30	35	40
0.2MPa Refractoriness Under Load, °C	≥	1650	1660	1670

Silicon Carbide Brick



Good Thermal
Shock Stability



High Working
Temperature



Great Wear
Resistance



Low Thermal
Expansion Coefficient

Application:

Silicon carbide brick is mainly used for making non-ferrous metallurgical retorts, aluminum casting molds, electric furnace linings, aluminum electrolytic cell linings, ceramic kiln furniture and heat exchangers, etc.

Technical Data:

Item/Grade		Index
SiC, %	≥	85
Fe ₂ O ₃ , %	≤	0.5
Apparent Porosity, %	≤	16
0.2MPa Refractoriness Under Load, °C	≥	1750
Bulk Density, g/cm ³	≥	2.6
Cold Crushing Strength, MPa	≥	80
Modulus of Rupture, MPa	≥	40

Chromic Oxide Brick



High Working
Temperature



Good Thermal
Shock Resistance



Great Wear
Resistance



Good Corrosion
Resistance

Application:

High chromium bricks are mainly used for lining and reinforcement of different blast furnaces, kilns, electric furnaces, boilers, etc. in the metallurgical industry, cement industry, chemical industry, non-ferrous metal and glass industries.

Technical Data:

Item		GGZ-75	GGZ-85	GGZ-90	GGZ-95
Cr ₂ O ₃ , %	≥	75	85	90	95
Cr ₂ O ₃ +Al ₂ O ₃ +ZrO ₂ , %	≥	98	98	98	98
SiO ₂ , %	≤	0.2	0.2	0.2	0.2
Fe ₂ O ₃ , %	≥	0.3	0.3	0.3	0.3
K ₂ O+Na ₂ O, %	≥	0.2	0.2	0.2	0.2
Bulk Density, g/cm ³	≥	3.9	4.2	4.22	4.25
Apparent Porosity, %	≤	18	18	16	16
Cold Crushing Strength, MPa	≥	120	120	120	120

Alumina Silicon Carbide Brick



High Working
Temperature



Good Thermal
Shock Resistance



Great Wear
Resistance



High Temperature
Compressive Strength

Application:

Alumina silicon carbide brick can be used as the supporting material for the lining of wire quenching heating furnace and the corundum silicon carbide slide rail brick for steel rolling heating furnace. It can also be used as kiln furniture for ceramic firing.

Technical Data:

Item		Gm1650	Gm1600	Gm1550
Al ₂ O ₃ , %	≥	65	63	60
Bulk Density, g/cm ³	≥	2.65	2.60	2.55
Apparent Porosity, %	≤	17	17	19
Cold Crushing Strength, MPa	≥	85	90	90
0.2MPa Refractoriness Under Load, °C	≥	1650	1600	1550
Thermal Shock Resistances (1100°C, Water Cooling), Cycle	≥	10	10	12
Resistance to Abrasion at Ambient Temperature, cm ³	≤	5	5	5

Silicon Nitride Bonded Silicon Carbide Brick



High Working
Temperature



Good Thermal
Shock Resistance



Great Wear
Resistance



Good Alkali
Corrosion Resistance

Application:

Silicon nitride bonded silicon carbide brick is mainly used as the lining of the lower furnace body of the blast furnace, the lining of the aluminum reduction electrolytic cell, ceramic kiln furniture, and the blast furnace tuyere water cooling pipe sleeve.

Technical Data:

Item		Index
SiC, %	≥	72
Si ₃ N ₄ , %	≥	21
Fe ₂ O ₃ , %	≤	0.5
Apparent Porosity, %	≤	18
Bulk Density, g/cm ³	≥	2.65
Cold Crushing Strength, MPa	≥	150
Modulus of Rupture, MPa	≥	40

Acid Proof Brick



Low Water
Absorption



Chemical Corrosion
Resistance



Mechanical
Strength

Application:

Acid Proof/Resistant Brick is anti corrosive and acid resistant material, which uses quartz, feldspar and clay as main raw materials and is fired by high temperature. Acid proof brick main component is SiO₂. When SiO₂ is burned in high temperature, there are lots of Polychlorite andalusite which can resist acids strongly. Acid resistant brick also can resist alkali at room temperature because of high density, low water absorption. But it does not resist alkali at high temperature.

Technical Data:

Item		Index
Acid Resistance, %	≥	99.8
Bulk Density, g/cm ³		2.31-2.4
Water Absorption, %	≤	2
Bending Strength, Mpa	≥	58.8
Compressive Strength, Mpa		120
Thermal Shock Resistance, Cycles (130°C-20°C)	≥	1



High Fire
Resistance



Customized
Production Available



Great Wear
Resistance



Good Alkali
Corrosion Resistance

Application:

According to the material, there are high alumina refractory balls, corundum refractory balls, silica refractory balls, magnesium refractory balls, mullite refractory balls, etc. Refractory balls can be used in high temperature conversion furnaces, conversion furnaces, hot air furnaces of fertilizer plants, etc.

Technical Data:

Item	High Alumina	Low Creep	Mullite	Corundum
Al ₂ O ₃ , %	65	70	75	95
Refractoriness under load, °C	1450	1460	1530	1650
Apparent Porosity, %	25	23	22	18
Bulk Density, g/cm ³	2.3	2.4	2.5	3.1
Cold crushing strength, Mpa	13	14	32	36
Thermal shock resistance (1100°C water cooling), cycle ≥	≥15	≥10	≥20	≥7
Refractoriness, °C	1710	1750	1800	1800



Insulation Brick

Serving the Global High-temperature Industry

High Alumina Insulation Brick



Low Volume
Density



Lower Thermal
Conductivity



Excellent Heat
Insulation



Significant Energy
Saving Effect

Application:

Used in insulation layer of industrial kilns like ceramic tunnel kilns, roller kilns, shuttle kilns, wall kilns, as well as other locations without strong erosion of high-temperature molten materials.

Technical Data:

Item/Grade		Lg140 -1.2	Lg140 -1.0	Lg140 -0.8L
Al ₂ O ₃ , %	≥	48		
Fe ₂ O ₃ , %	≤	2.0		
Bulk Density, g/cm ³	≤	1.2	1	0.8
Cold Crushing Strength, MPa	≥	4.5	3.5	2.5
Permanent Linear Change, % (T/°C*12h)	Test Temperature T/°C	1400		
Thermal Conductivity Coefficient, W/(m·K) Average Temperature (350±25°C)	≤	0.55	0.50	0.35

Fire Clay Insulation Brick



Lower Thermal
Conductivity



High Porosity,
Low Volume Density



Good Thermal
Shock Resistance



Good Heat
Insulating Effect

Application:

Widely used as the insulation layer of thermal equipment such as ignition kilns, flues, refining devices, heating devices, gas furnaces and pipelines, soaking furnaces, annealing furnaces, reaction chambers, etc.

Technical Data:

Item/Grade		NG135 -1.3	NG135 -1.2	NG130 -1.0	NG125 -0.8	NG120 -0.6
Bulk Density, g/cm ³	≥	1.3	1.2	1.0	0.8	0.6
Cold Crushing Strength, MPa	≤	5	4.5	3.5	2.5	1.3
	/	4.5	4.0	3.0	2.0	1.0
Permanent Linear Change, %	Experimental Conditions	1350°C*12h		1300°C* 12h	1250°C* 12h	1200°C* 12h
	Xmin~Xmax	-2-1				
Thermal Conductivity Coefficient , W/(m·K) ≤ Average Temperature (350±25°C)	≤	0.55	0.50	0.40	0.35	0.25

Mullite Insulation Brick



Lightweight and
High Strength



Good Thermal
Insulation Effect



Accurate and
Customized Dimension



Lower Thermal
Conductivity



Good Thermal
Shock Resistance

Application:

Suitable for the refractory lining and backing insulation layer of pyrolysis furnaces, hot blast furnaces, ceramic roller kilns, electric porcelain drawer kilns and various industrial resistance furnaces.

Technical Data:

Item/Grade		KR-23			
Type		A	B	C	D
Al ₂ O ₃ , %	≥	42	42	45	48
Fe ₂ O ₃ , %	≤	1.2	1.2	1	1
Bulk Density, g/cm ³		0.55	0.6	0.8	1.0
Reheating Linear Change, %	≤	-0.5	-0.55	-0.4	-0.3
		1230°C x12h	1260°C x12h	1300°C x12h	1300°C x12h
Cold Compression Strength, MPa	≥	1.2	1.5	2.3	3
Thermal conductivity 350 °C , W/(m·K)		0.17	0.19	0.24	0.31

Item/Grade		KR-26			
Type		A	B	C	D
Al ₂ O ₃ , %	≥	54	55	56	56
Fe ₂ O ₃ , %	≤	0.9	0.9	1	1
Bulk Density, g/cm ³		0.7	0.8	0.9	1.0
Reheating Linear Change, %	≤	-1	-0.65	-0.5	-0.5
		1400°C x12h			
Cold Compression Strength, MPa	≥	2	2.3	2.8	3.2
Thermal conductivity 350 °C , W/(m·K)		0.21	0.25	0.3	0.32

Item/Grade		KR-28			KR-30	
Type		A	B	C	A	B
Al ₂ O ₃ , %	≥	64	65	66	72	72
Fe ₂ O ₃ , %	≤	0.75	0.65	0.65	0.55	0.55
Bulk Density, g/cm ³		0.8	0.9	1.0	1.0	1.1
Reheating Linear Change, %	≤	-1	-0.8	-0.7	-0.9	-0.7
		1500°C x12h			1600°C x12h	
Cold Compression Strength, MPa	≥	2.3	2.8	3.3	3.0	3.5
Thermal conductivity 350 °C , W/(m·K)		0.28	0.32	0.34	0.4	0.43

Alumina Bubble Brick



High Crushing
Strength



High Working
Temperature



Good Thermal
Shock Resistance



Good Thermal
Stability



Lightweight and
Energy-saving



Lower Thermal
Conductivity

Application:

Commonly used as the working layer and heat insulation layer of high temperature kilns in petrochemical industry gasifiers, carbon black reactors, metallurgical induction furnaces and other industries.

Technical Data:

Item/Grade		85	90	99
Max Service Temperature, °C		1680	1700	1800
Al ₂ O ₃ , %	≥	85	90	99
SiO ₂ , %	≤	13	8	0.2
Fe ₂ O ₃ , %	≤	0.2	0.2	0.2
Bulk Density, g/cm ³		1.4-1.7	1.4-1.7	1.4-1.7
Cold Crushing Strength, Mpa	≥	12	10	9
Refractoriness Under Load(0.1MPa.0.6%), °C	≥	1650	1700	1700
Reheating Linear Change(1600°Cx3h), %		±0.3	±0.3	±0.3
Thermal Expansion Coefficient (Room temp-1300°C)		~7.8	~8.0	~8.6
Thermal Conductivity Coefficient (1800°C), W/(m·K)	≤	0.8	1.3	1.5

Silica Insulation Brick



Great Thermal
Mechanical Strength



Strong Acid Slag
Erosion Resistance



Good Thermal
Stability



Lower Thermal
Conductivity



Lightweight and
Energy-saving

Application:

Commonly used in coke oven insulation layers, glass kiln vaults, hot blast furnace walls and domes. It does not directly contact high-temperature molten materials and alkaline gas working layers.

Technical Data:

Item/Grade		GGR-1.00	GGR-1.10	GGR-1.15	GGR-1.20
SiO ₂ , %	≥	91	91	91	91
Bulk Density, g/cm ³	≥	1.00	1.10	1.15	1.20
Cold Crushing Strength, MPa	≥	2.0	3.0	5.0	5.0
Permanent Linear Change On Reheating, °C	≤	/	/	0.5	0.5
0.1MPa Refractoriness Underload, °C	≥1500°C, 2h	0.5	0.5	/	/
	≥1450°C, 2h	1400	1420	1500	1520
Thermal Conductivity Coefficient, W/(m·K) Average Temperature (350±10°C)	≤	0.55	0.60	0.65	0.70

Monolithic Refractory

Serving the Global High-temperature Industry

Calcium Aluminate Cement



High Heat Resistance



Environmentally Friendly



Rapid Hardening



Easy Construction

Application:

In high temperature industries, refractory cement for sale is an important and popular product. Because it has wide applications in manufacturing monolithic refractory products and directly using in kilns.

CA-50 series Technical Data:

Item			A600	A700	A900
SiO ₂ , %	≤		7.8	7.5	5.5
Al ₂ O ₃ , %	≥		50.0	51.0	53.5
Fe ₂ O ₃ , %	≤		2.5	2.5	2.5
R ₂ O, %	≤		0.4	0.4	0.4
S, %	≤		0.1	0.1	0.1
Cl, %	≤		0.1	0.1	0.1
325M Residue on Sieve, %	≤		15	12	8
S, m ² /kg	≥		300	320	350
Initial Setting Time, min	≥		45	60	90
Final Setting Time, h	≤		6	6	6
Flexural Strength, Mpa	1d	≥	6.0	6.5	8.0
	3d	≥	7.0	7.5	10.0
Compressive Strength, Mpa	1d	≥	45	55	72
	3d	≥	55	65	82

Calcium Aluminate Cement

CA-70 Technical Data:

Item	CA70	
Properties Determined according to GB201-2000		
SiO ₂ , %	≤0.5	
Al ₂ O ₃ , %	68.5-70.5	
Fe ₂ O ₃ , %	≤0.2	
CaO, %	28.5-30.5	
MgO, %	≤0.4	
R ₂ O, %	≤0.4	
Fineness	D50, μm	11-14
	-45μm, %	≤8.0
Setting Time, min	Initial Setting, IS	120-180
	Final Setting, FS	150-240
Flexural Strength, Mpa	1d	7.5-10.0
	3d	10.0-12.0
Compressive Strength, Mpa	1d	40-50
	3d	45-55
Cement Properties in Testing Castables		
Setting Time, min	20°C	60-90
	35°C	30-50
Vibration Flow, mm (20°C)	Initial Flow	265-275
	10min	255-265
	30min	235-245
	60min	230-240
Flexural Strength, Mpa	20°C×24h	4.5-5.5
	110°C×24h	10.0-11.5
	1100°C×4h	12.0-14.0
Compressive Strength, Mpa	20°C×24h	35-45
	110°C×24h	85-95
	1100°C×4h	100-120
Linear Change, %	1100°C×4h	≤-0.25

CA-80 Technical Data:

Item	CA80	
Properties Determined according to GB201-2000		
SiO ₂ , %	≤0.5	
Al ₂ O ₃ , %	78.0-81.0	
Fe ₂ O ₃ , %	≤0.2	
CaO, %	17.5-20.5	
MgO, %	≤0.4	
R ₂ O, %	≤0.4	
Fineness	D50, μm	5-8
	-45μm, %	≤5.0
Setting Time, min	Initial Setting, IS	30-90
	Final Setting, FS	90-180
Flexural Strength, Mpa	1d	5.0-7.5
	3d	6.0-8.5
Compressive Strength, Mpa	1d	30-40
	3d	40-50
Cement Properties in Testing Castables		
Setting Time, min	20°C	90-120
	35°C	40-60
Vibration Flow, mm (20°C)	Initial Flow	255-265
	10min	250-260
	30min	240-250
	60min	235-245
Flexural Strength, Mpa	20°C×24h	3.0-4.0
	110°C×24h	8.0-9.0
	1100°C×4h	11.0-13.0
Compressive Strength, Mpa	20°C×24h	25-35
	110°C×24h	60-70
	1100°C×4h	100-120
Linear Change, %	1100°C×4h	≤-0.15

CA50 Fused Cement



High Heat
Resistance



Environmentally
Friendly



Rapid Hardening



Easy Construction

Application:

In high temperature industries, refractory cement for sale is an important and popular product. Because it has wide applications in manufacturing monolithic refractory products and directly using in kilns.

CA50 series Technical Data:

Item			CA50
Al ₂ O ₃ , %		≥	52
SiO ₂ , %		≤	8
Fe ₂ O ₃ , %		≤	2.5
CaO, %		≤	32
R ₂ O, %		≤	0.4
Flexural Strength, Mpa	1d	/	6
	3d	/	7
Compressive Strength, Mpa	1d	/	45
	3d	/	55
Initial Setting Time, min		>	30
Final Setting Time, h		<	360
Packing		/	25kgs bag with jumbag

High Alumina Castable



High-Temperature
Resistance



Impact
Resistance



Excellent Chemical
Resistance



Great Wear
Resistance

Application:

The appearance of high alumina refractory castables is powdery and sandy, which belongs to unshaped refractory materials. It is made of high-alumina raw materials as aggregate, powder, and binder to form a uniform mixture that can be easily molded and installed in various high-temperature applications.

Technical Data:

Item		G-15B	G-15	G-16
Maximum service temperature, °C		1400	1500	1600
Al ₂ O ₃ , %		≥65	≥75	≥78
SiO ₂ , %		25	20	15
B.D After Drying at 110°C, g/cm ³		2.50	2.60	2.65
Cold Bending Strength, Mpa	110°C, X24h	8	8	10
	1100°C, X3h	8	8	10
Cold Compressive Strength, Mpa	110°C, X24h	70	80	100
	1100°C, X3h	70	80	100
Linear Change Rate After Burning PLC, %	1100°C, X3h	±0.3	±0.3	±0.3
Construction Reference Water Consumption, %		6-7	6-7	5.5-6.5

Aluminum Magnesium Refractory Castable



High-Temperature
Resistance



Customized
Production Available



Great Wear
Resistance



Strong Resistance to
Erosion and Permeability

Application:

Aluminum-magnesium refractory castable is made of fused magnesia, sintered magnesia, fused or sintered magnesia alumina spinel, fused alumina powder, high alumina powder, etc. According to the different quality of raw materials used, it can be divided into: ordinary aluminum-magnesium castable, ordinary high aluminum-spinel castable, alumina-magnesia castable, alumina-spinel castable, corundum spinel castable.

Technical Data:

Item		AMC-70	AMC-80	AMC-85	AMC-95
Al ₂ O ₃ +Mgo, %	≥	70	80	85	95
Bulk density(110°C×24h), g/cm ³	≥	2.6	2.8	2.85	2.95
Cold Bending Strength, Mpa	110°C×24h, ≥	20	20	20	20
	1000°C×3h, ≥	30	30	30	30
	Test temp×3h, ≥	50(1500°C)	50(1550°C)	60(1550°C)	60(1600°C)
Heating permanent line change, %	Test temp×3h	-0.5~+1.5 (1500°C)	-0.5~+1.8 (1550°C)	-0.2~+1.8 (1550°C)	0~+1.0 (1600°C)



Low Thermal
Expansion



Environmentally
Friendly



Short Bake Time,
No cracking



Good Wear
Resistance

Application:

Mullite refractory castable is an unshaped refractory material composed of porous mullite aggregate, binder, and various additives. Mullite is a high-quality refractory raw material, and this type of mineral is relatively rare.

Technical Data:

Item		ML-70	ML-80	ML-90
Maximum service temperature, °C		1600	1600	1750
Al ₂ O ₃ +SiO ₂ , %		≥70	≥80	≥90
B.D After Drying at 110°C, g/cm ³		2.70	2.80	2.90
Cold Bending Strength, Mpa	110°C, X24h	10	12	15
Cold Compressive Strength, Mpa	110°C, X24h	100	100	150
Linear Change Rate After Burning PLC, %	1100°C, X3h	±0.3	±0.3	±0.3
	1500°C, X3h	±0.5	±0.5	±0.5
Construction Reference Water Consumption, %		4.5-5	4.5-5	4.5-5

Corundum Castable



Corrosion
Resistance



High-Pressure
Strength



Good Volume
Stability



Excellent Mechanical
Strength

Application:

Corundum refractory castable is an unshaped refractory material formed by mixing corundum and super bauxite clinker as aggregate and powder, plus some pure calcium aluminate cement, as well as binders and additives.

Technical Data:

Item		G-17	G-18S	G-18
Maximum service temperature, °C		1650	1650	1700
Al ₂ O ₃ , %		≥85	≥90	≥93
SiO ₂ , %		8	4	2
B.D After Drying at 110°C, g/cm ³		2.90	3.00	3.00
Cold Bending Strength, Mpa	110°C, X24h	9	12	14
Cold Compressive Strength, Mpa	110°C, X24h	80	90	100
Linear Change Rate After Burning PLC, %	1100°C, X3h	±0.3	±0.3	±0.2
	1500°C, X3h	±0.6	±0.6	±0.5
Construction Reference Water Consumption, %		4.5-5.5	5-6	5.5-6.5

Silicon Carbide Castable



High-Temperature
Resistance



Good resistance
to erosion



Abrasiveness
resistance



High
strength

Application:

Silicon Carbide Castable are made from high-grade silicon carbide and industrial silicon powder as raw materials. Which is one of the unshaped refractory materials. It is one of the new type refractory material of don't need calcination.

Technical Data:

Item		CG-13	CG-13H	CG-17
Maximum service temperature, °C		1300	1400	1600
Al ₂ O ₃ , %		≤35	≤25	75
SiC, %		≥30 SiC	≥50 SiC	/
B.D After Drying at 110°C, g/cm ³		2.40	2.50	2.70
Cold Bending Strength, Mpa	110°C, X24h	9	8	10
	1100°C, X3h	9	9	11
Cold Compressive Strength, Mpa	110°C, X24h	80	70	100
	1100°C, X3h	80	80	110
Linear Change Rate After Burning PLC, %	1100°C, X3h	±0.3	±0.4	±0.4
Construction Reference Water Consumption, %		6-7	6-7	5-6

Lightweight Insulating Castable



Lightweight
easier to handle



Low Thermal
Expansion



Good Thermal
Shock Resistance

Application:

Lightweight thermal insulation castables are composed of refractory lightweight aggregate and powder, as well as binders, additives, etc. s

Technical Data:

Item		QG-1.0	QG-0.8	QG-0.6
Maximum service temperature, °C		1250	1200	1150
Al ₂ O ₃ , %		43	40	36
SiO ₂ , %		36	37	30
Bulk Density, g/cm ³		1.0	0.8	0.5
Thermal Conductivity Coefficient, W/(m·K)	350°C	≤0.3	≤0.25	≤0.15
	700°C	≤0.4	≤0.30	≤0.20
Cold Crushing Strength, MPa	110°C*24h	≥4.0	≥2.0	≥1.5
	1000°C*3h	≥5.5	≥2.0	≥1.5
Permanent Linear Change (1000°C*3h)/%		-1.0	-1.0	-1.5



Good thermal shock resistance.



Excellent corrosion resistance.



High-Pressure Strength



Good volume stability.

Application:

Wear resistant castable is a kind of refractory castable that has a high wear resistance and a high abrasion resistance. This product is made of calcium aluminate cement and refractory powder with a high alumina content or other hard materials as the main component.

Technical Data:

Item		GQ-75	GQ-85	GQ-90
Al ₂ O ₃ , %		75	85	90
B.D After Drying at 110°C, g/cm ³		2.75	2.90	3.00
Cold Bending Strength, Mpa	110°C, X24h	11	15	15
	1100°C, X3h	12	16	17
Cold Compressive Strength, Mpa	110°C, X24h	120	140	150
	1100°C, X3h	120	120	120
Linear Change Rate After Burning PLC, %	1100°C, X3h	±0.4	±0.3	±0.2
Construction Reference Water Consumption, %		5.5-6.5	4.5-6.5	4.5-6.5

Ceramic Fiber Products

Serving the Global High-temperature Industry



Ceramic Fiber Blanket



High-Temperature
Stability



Excellent Thermal
Insulation Properties



Free of Binders and
Corrosive Substances



Excellent Sound
Absorption

Application:

The ceramic fiber blanket is white in color, regular in size, integrated with heat insulation, and heat preservation functions, and does not contain any additives.

Technical Data:

Item	Common Type	Standard Type	High Purity Type	High Alumina Type	Zirconium Containing Type
Classification Temperature, °C	1050	1260	1260	1350	1430
Service Temperature, °C	<1000	1050	1100	1200	1350
Bulk & Density, kg/m ³	96-128	96-128	96-128	128-160	128-160
Permanent Liner Change, %	-4(1000°C)	-3(1000°C)	-3(1100°C)	-3(1250°C)	-3(1350°C)
Thermal Conductivity Under Each Section, W/(m·k) (Bulk density 128kg/m ³)	0.09 (400°C) 0.176 (800°C)	0.09 (400°C) 0.176 (800°C)	0.09 (400°C) 0.176 (800°C) 0.22 (1000°C)	0.132 (600°C) 0.22 (1000°C)	0.76 (800°C) 0.20 (1000°C)
Strength of Extension, Mpa	0.08-0.12	0.08-0.12	0.08-0.12	0.08-0.12	0.08-0.12
Al ₂ O ₃ , %	44	46	47-49	52-55	39-40
Al ₂ O ₃ +SiO ₂ , %	96	97	99	99	-
Al ₂ O ₃ +SiO ₂ +ZrO ₂ , %	-	-	-	-	99
ZrO ₂ , %	-	-	-	-	15~17
Fe ₂ O ₃ , %	<1.2	<1.0	0.2	0.2	0.2
Na ₂ O+K ₂ O, %	≤0.5	≤0.5	0.2	0.2	0.2
Size, mm	Standard Size:7200*610*6-60, Customized Sizes				

Ceramic Fiber Board

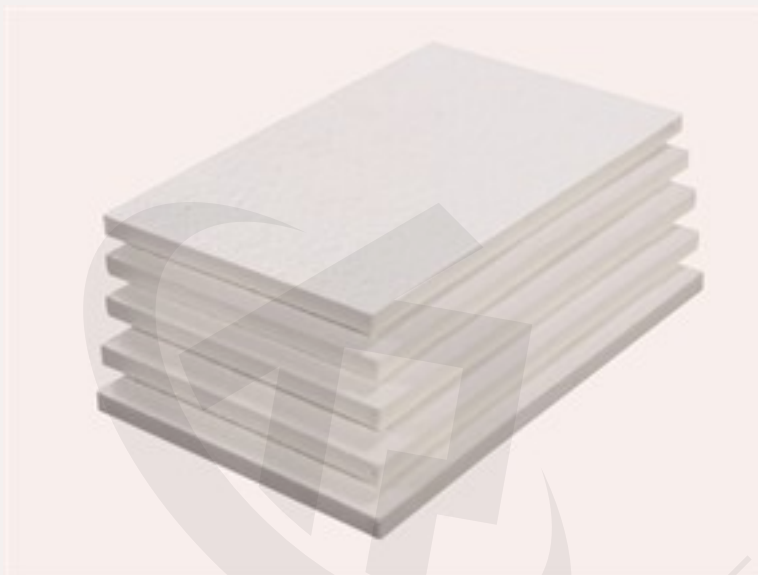

Lightweight
High Strength.



High Compressive
Strength



Evenly Heated



Good Toughness

Application:

Ceramic fiber board is a kind of refractory material, usually composed of alumina and silicate, and it is also called an aluminum silicate board.

Technical Data:

Item	Ordinary Type	Standard Type	High Purity Type	High Alumina Type	Zirconium Containing Type
Classification Temperature, °C	1100	1260	1260	1360	1430
Working Temperature, °C	<1000	1050	1100	1200	1350
Bulk & Density, kg/m ³	260-320	260-320	260-320	260-320	260-320
Permanent Liner Change, %	-4(1000°C)	-3(1000°C)	-3(1000°C)	-3(1250°C)	-3(1350°C)
Heat Conductivity Coefficient, W/(m·k) (Bulk density 128kg/m ³)	0.09 (400°C),		0.176 (800°C),	0.22 (1000°C)	
Strength of Extension, Mpa	0.5	0.5	0.5	0.5	0.5
Al ₂ O ₃ , %	44	46	46~49	52-55	39-40
Al ₂ O ₃ +SiO ₂ , %	96	97	99	99	-
Al ₂ O ₃ +SiO ₂ +ZrO ₂ , %	-	-	-	-	99
ZrO ₂ , %	-	-	-	-	15~17
Fe ₂ O ₃ , %	<1.2	<1.0	0.2	0.2	0.2
Na ₂ O+K ₂ O, %	≤0.5	≤0.5	0.2	0.2	0.2
Size, mm	Length, Width Regular Size, Thickness 3-100mm, Customized Size				



Metal Erosion
Ability



Non-Toxic, Harmless,
And Odorless



Electrical Insulation
Properties



Acid and Alkali
Corrosion Resistance

Application:

Ceramic fiber cloth is a woven fabric made of ceramic fiber yarn. The main raw materials include alumina, silicate or borate, etc. It has excellent heat resistance and chemical stability.

Technical Data:

Item	Ceramic Fiber Cloth		Ceramic Fiber Tape	
	Glass Fiber	Stainless Steel	Glass Fiber	Stainless Steel
Physical Property	Glass Fiber	Stainless Steel	Glass Fiber	Stainless Steel
Bulk Density, kg/m ³	500		500	
Size, mm	30000 x 1000 x 2/3		30000 x 50/75 x 2/3	
Moisture Content, %	≤2		≤2	
Continuous Temperature Use Limit, °C	650	1050	600	1050
Organic Content, %	≤15		≤15	



Thermal Shock
Resistance



High-Temperature
Resistance



Electrical
Insulation



Environmental
Friendly

Application:

Ceramic fiber paper is a paper refractory product made of ceramic fibers, also called aluminum silicate fiber paper. Ceramic fiber paper is a high-temperature refractory material, usually made of inorganic oxide fibers,

Technical Data:

Item		STD Paper	HD Paper
Classification Temperature, °C		1260	1350
Al ₂ O ₃ , %		42-47	44-50
SiO ₂ , %		52-57	49-55
Color		White	White
Bulk Density, kg/m ³		200	240
Tensile Strength, MPa		0.4	0.7
Loss of Ignition, %		≤10	≤6
Thermal Conductivity Coefficient, W/(m·K)	200°C	0.06	0.06
	400°C	0.09	0.08
	600°C	0.13	0.13
	800°C	0.20	0.19
	1000°C	/	0.29
	1200°C	/	0.43

Ceramic Fiber Rope



High-Temperature
Stability



Chemical
Resistance



Efficient
Insulation



Sound
Insulation

Application:

Ceramic fiber rope is made of ceramic fiber spun yarn and is often used as heat insulation material. It is an excellent substitute for asbestos rope. Ceramic fiber rope can be divided into twisted rope, square rope, and round rope.

Technical Data:

Item	Round Braided Rope		Square Braided Rope		Twisted Rope		Woolen Rope
	Glass Fiber	Stainless Steel	Glass Fiber	Stainless Steel	Glass Fiber	Stainless Steel	Glass Fiber
Reinforcement	Glass Fiber	Stainless Steel	Glass Fiber	Stainless Steel	Glass Fiber	Stainless Steel	Glass Fiber
Continuous Temperature Use Limit, °C	650	1000	650	1000	650	1000	650
Color	White		White		White		White
Bulk Density, kg/m ³	500		500		300		380
Organic Content, %	15		15		≤15		≤15



Good Thermal Shock Resistance



Environmentally Friendly



Low Thermal Conductivity



Good Chemical Stability

Application:

Ceramic fiber cotton is made of high-purity silicon and aluminum raw materials using spinning or blowing processes. In addition, in the vacuum forming process, ceramic bulk fiber is the basis for ceramic fiber blankets, boards, papers and other products.

Technical Data:

Item	STD BULK			HP BULK	HA BULK	HZ BULK
	Spun	Blown	Chopped			
Classification Temperature, °C	1260	1260	1260	1260	1350	1430
Al ₂ O ₃ , %	≥43	≥43	≥43	≥44	≥52	≥35
SiO ₂ , %	≥54	≥54	≥54	≥55	≥47	≥49
ZrO ₂ , %	-					≥15
Color	White					
Shot Content, %	≤15	≤15	≤12	≤15	≤15	≤12
Fiber Diameter, μm	3-5	2-4	2-4	3-5	2-4	3-5

Ceramic Fiber Module



Low Thermal
Conductivity



Shock
Resistance



Great Wear
Resistance



Easy
Installation

Application:

Ceramic fiber module uses advanced ceramic fiber technology to optimize the fiber fineness and structure to provide excellent thermal insulation performance and durability. It is made of ceramic fiber blankets that are folded or stacked and pressed into rectangular modules and employs non-exposed anchorage for economical installation and mechanical linkage.

Technical Data:

Item	STD Module	HP Module	HA Module	HZ Module
Classification Temperature, °C	1260	1260	1350	1430
Al ₂ O ₃ , %	≥43	≥44	≥52	≥35
SiO ₂ , %	≥54	≥55	≥47	≥49
ZrO ₂ , %	-	-	-	≥15
Color	White	White	White	White
Bulk Density, kg/m ³	160-220	160-220	160-220	160-220
Permanent Linear Change, %	1000°C*24h ≤2.5	1100°C*24h ≤2.5	1200°C*24h ≤2.5	1350°C*24h ≤2.5
Chemical Composition	400°C	0.10	0.10	0.10
	600°C	0.18	0.17	0.16
	800°C	0.20	0.20	0.20
	1000°C	0.27	0.26	0.26

Calcium Silicate Board



Excellent Fire
Performance



Excellent impact
resistant



Superior Heat
Insulation



Low Thermal
Conductivity

Application:

Calcium silicate board is a new type of lightweight multi-purpose board, which is made of silicon materials, calcium materials, reinforcing fibers, etc. Calcium silicate board can be used in high temperature kilns directly to block the transfer of heat.

Technical Data:

Item	Calcium Silicate Insulation Board			
Maximum Use Temperature, °C	1000			
SiO ₂ , %	46-48			
CaO, %	37-41			
Al ₂ O ₃ , %	0.39-0.42			
MgO, %	0.5-0.7			
Bulk Density, kg/m ³	230±10%	250±10%	270±10%	
Modules of Rupture, MPa	≥ 0.45	0.50	0.55	
Compressive Strength, MPa	≥ 0.75	0.85	0.95	
Permanent Linear Change, %	1000°C*16h ≤ 2.0			
Thermal Conductivity Coefficient, W/(m·K)	100 °C	0.065	0.067	0.072
	400 °C	0.091	0.077	0.082
	600 °C	0.132	0.136	0.138



High temperature
up to 1800°C



Resistant to sudden
cold and hot



High chemical
etching resistance.



Various kinds
of shape

Application:

Alumina ceramics are ceramic materials based on alumina (Al_2O_3) for thick film integrated circuits. Alumina ceramics have good conductivity, mechanical strength and high temperature resistance.

Technical Data:

Item	Alumina				
	AL997	AL995	AL99	AL95	AL60
Index	AL997	AL995	AL99	AL95	AL60
Main Ingredient Content	99.70%	99.5%	99.0%	95%	60%
Air Tightness	Airtight	Airtight	Airtight	Airtight	Airtight
Bulk Density, kg/m^3	3.94	3.9	3.8	3.75	3
Hardness	9	9	9	8.8	7.5
Water Absorption	≤ 0.2	≤ 0.2	≤ 0.2	≤ 0.2	≤ 0.2
Flexural Strength, 20°C	375	370	340	304	205
Compressive Strength, 20°C	2300	2300	2210	1910	1820
Thermal Expansion Coefficient, 25°C-800°C	7.6	7.6	7.6	7.6	7.1
Dielectric Strength, 5mm	10	10	10	10	9
Dielectric Loss, 25°C @MHZ	<0.0001	<0.0001	0.0006	0.0004	0.0007
Permittivity, 25°C @MHZ	9.8	9.7	9.5	9.2	8.6
Volume Resistivity, 20°C	$>10^{14}$ $2*10^{12}$	$>10^{14}$ $2*10^{12}$	$>10^{14}$ $4*10^{11}$	$>10^{14}$ $2*10^{11}$	$>10^{14}$ $>10^{13}$
Long-term Use Temperature, °C	1700	1650	1600	1400	1100
Thermal Conductivity 25°C, W/(m·K)	35	35	34	20	16

Item	MgO	Mullite	ZrO ₂	Si ₃ N ₄
Main Ingredient Content	-	-	-	<92%
Air Tightness	Airtight	Airtight	Airtight	Airtight
Bulk Density, kg/m ³	3.58	2.6	6.01	3.1
Hardness	6	8	8.5	9.4
Water Absorption	0	0	0	0
Flexural Strength, 20°C	140	120	1200	150
Compressive Strength, 20°C	550	500	5700	490
Thermal Expansion Coefficient, 25°C-800°C	13	5.6	10	2.9
Dielectric Strength, 5mm	-	10.2	-	-
Dielectric Loss, 25°C @MHZ	-	0.002	0.001	0.001-0.1
Permittivity, 25°C @MHZ	-	6	29	8.3
Volume Resistivity, 20°C	>10 ¹⁴	>10 ¹⁴ 5*10 ¹²	>10 ¹³ 5*10 ⁸	10 ¹¹ -10 ¹² 4*10 ⁸
Long-term Use Temperature, °C	2300	1600	1600	1300
Thermal Conductivity 25°C, W/(m·K)	36	3.6	3	9.46

Item	Recrystallized Silicon Carbide	Silicon Nitride Bonded Silicon Carbide	Boron Nitride
Main Ingredient Content	-	-	<99.2%
Air Tightness	-	Airtight	Apparent Porosity ≤0.1
Bulk Density, kg/m ³	2.7	2.8	2.0-2.2
Hardness	9.5	9	2
Water Absorption	0	0	0
Flexural Strength, 20°C	90	180	30
Compressive Strength, 20°C	600	650	58
Thermal Expansion Coefficient, 25°C-800°C	4.7	5	1.5
Dielectric Strength, 5mm	-	-	-
Dielectric Loss, 25°C @MHZ	-	-	0.00025
Permittivity, 25°C @MHZ	-	-	4
Volume Resistivity, 20°C	-	-	10 ⁸ -10 ¹⁴
Long-term Use Temperature, °C	1650	1450	In Air Is 900
Thermal Conductivity 25°C, W/(m·K)	23	15	30

Honeycomb Ceramic Regenerator

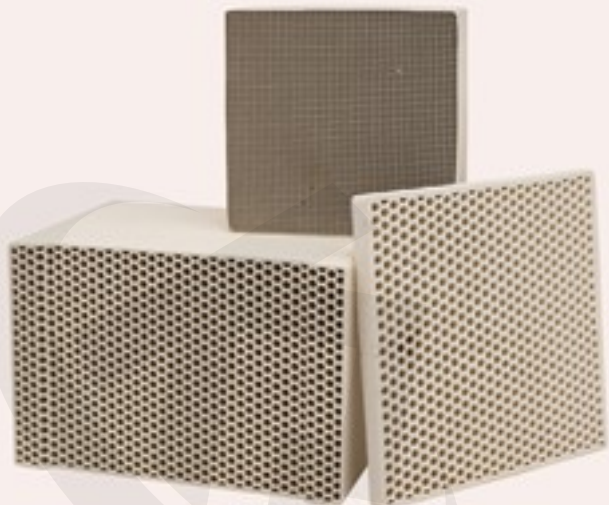

Good Thermal Stability



Environmental Protection



Long Service Life



High Strength

Application:

Regenerative high-temperature air combustion technology (HTAC for short) has the dual functions of energy saving and environmental protection. Compared with traditional combustion technology, it saves 20-50% of fuel, reduces oxidation and burning losses by more than 20%, and reduces NOx emissions by more than 40%.

Technical Data:

Item		Corundum -Mullite	Mullite	Cordierite -Mullite	Cordierite	Chrome Corundum -Mullite	Zirconium Corundum -Mullite
Bulk density, g/cm ³	≥	0.8	0.6-1.1	0.6-0.9	0.5-0.8	0.8	0.8
Thermal Expansion Coefficient , X10-60°C-1, RT-800°C	≤	6	5.5	3	2.5	6.5	6
Specific heat capacity, J.(Kg.k)-1	≥	800	800	750	750	800	800
Thermal Shock , °C	≥	300	300	400	500	300	350
Softening temperature under load, °C/ 0.1MPa	≥	1500	1450	1350	1250	1500	1500
Compressive Strength, Mpa / C axis	≥	20	20	20	20	20	20
Compressive Strength, Mpa/ A, B axis	≥	4	4	3	3	4	4

Ceramic Saddles & Supper Saddles



Good Thermal
Stability



Customized
Production Available



Long Service Life



High Strength

Application:

These products specifically apply to gas purification in the regenerative thermal oxidizer and the regenerative catalytic oxidizer. This type of ceramic media is commonly used in RTO, RCO or scrubber to provide heat retention by acting as a heat exchanger for preheating the incoming waste gas stream.

Technical Data:

Specification of Ceramic Saddles

Size		Deck Diameter (mm)	Outside Diameter (mm)	Height (mm)	Wall Thickness (mm)	Width (mm)
1/2"	12mm	12	20	10	2.0	10
5/8"	16mm	16	24	12	2.0	12
3/4"	19mm	19	28	14	2.5	14
1"	25mm	25	38	19	3.0	20
1.5"	38mm	38	60	30	4.0	30
2"	50mm	50	80	40	5.0	40
3"	76mm	76	114	57	9.0	57

Ceramic Saddles & Supper Saddles

Physical Performance of Ceramic Saddles

Item	1/2" 12mm	5/8" 16mm	3/4" 19mm	1" 25mm	1.5" 38mm	2" 50mm	3" 76mm
Number per, m ³	610,000	269,000	146,000	59,000	19,680	8,243	2,400
Bulk Density, kg/m ³	780	700	670	630	580	550	530
Free Space, %	68	71	75	77	80	79	75
Specific Surface Area, m ² /m ³	647	535	350	254	180	120	91
Density, g/m ³	2.3						
Water Absorption, %	<0.3						
Acid Resistance, %	>99.6						
Maximum Service Temperature	1100°C						
Porosity, %	<1						
Moh's Hardness	>6.5						
Specific Heat Capacity, J/g·K	850-900						
Thermal Conductivity, W/(m·K)	0.9-1.0						

Chemical Composition of Ceramic Saddles

Chemical Composition	Unit
SiO ₂ , %	>73
Al ₂ O ₃ , %	17-23
Fe ₂ O ₃ , %	<1.0
CaO, %	<0.5
MgO, %	<0.5
K ₂ O+Na ₂ O, %	2-4
Other %	<0.1

Ceramic Saddles & Supper Saddles

Specification of Ceramic Supper Saddles

Size		Deck Diameter (mm)	Outside Diameter (mm)	Height (mm)	Wall Thickness (mm)	Width (mm)
1"	25mm	25	38	19	3.0	20
1.5"	38mm	38	60	30	4.0	30
2"	50mm	50	80	40	5.0	40
3"	76mm	76	114	57	9.0	57

Physical Performance of Ceramic Supper Saddles

Item	1" 25mm	1.5" 38mm	2" 50mm	3" 76mm
Number per, m ³	39,000	21,500	8,500	3,000
Bulk Density, kg/m ³	645	600	570	580
Free Space, %	77	78	79	80
Specific Surface Area, m ² /m ³	260	210	140	105
Density, g/m ³	2.3			
Water Absorption, %	<0.2			
Acid Resistance, %	>99.98			
Maximum Service Temperature	1320°C			
Porosity, %	<1			
Moh's Hardness	7-8			
Specific Heat Capacity, J/g·K	840-900			
Softening Point	>1400°C			
Thermal Expansion	4.7x(10 ⁻⁶ /°C)			
Compressive strength, MPa	390-420			

Chemical Composition of Ceramic Supper Saddles

SiO ₂ , %	Al ₂ O ₃ , %	SiO ₂ +Al ₂ O ₃ , %	CaO, %	MgO, %	K ₂ O+Na ₂ O, %	Fe ₂ O ₃ , %	Other %
>69	15-23	>92	<0.25	<0.2	2-4	<1	<1

**RBSiC / SiSiC Silicon Carbide
Kiln Shelves Products**

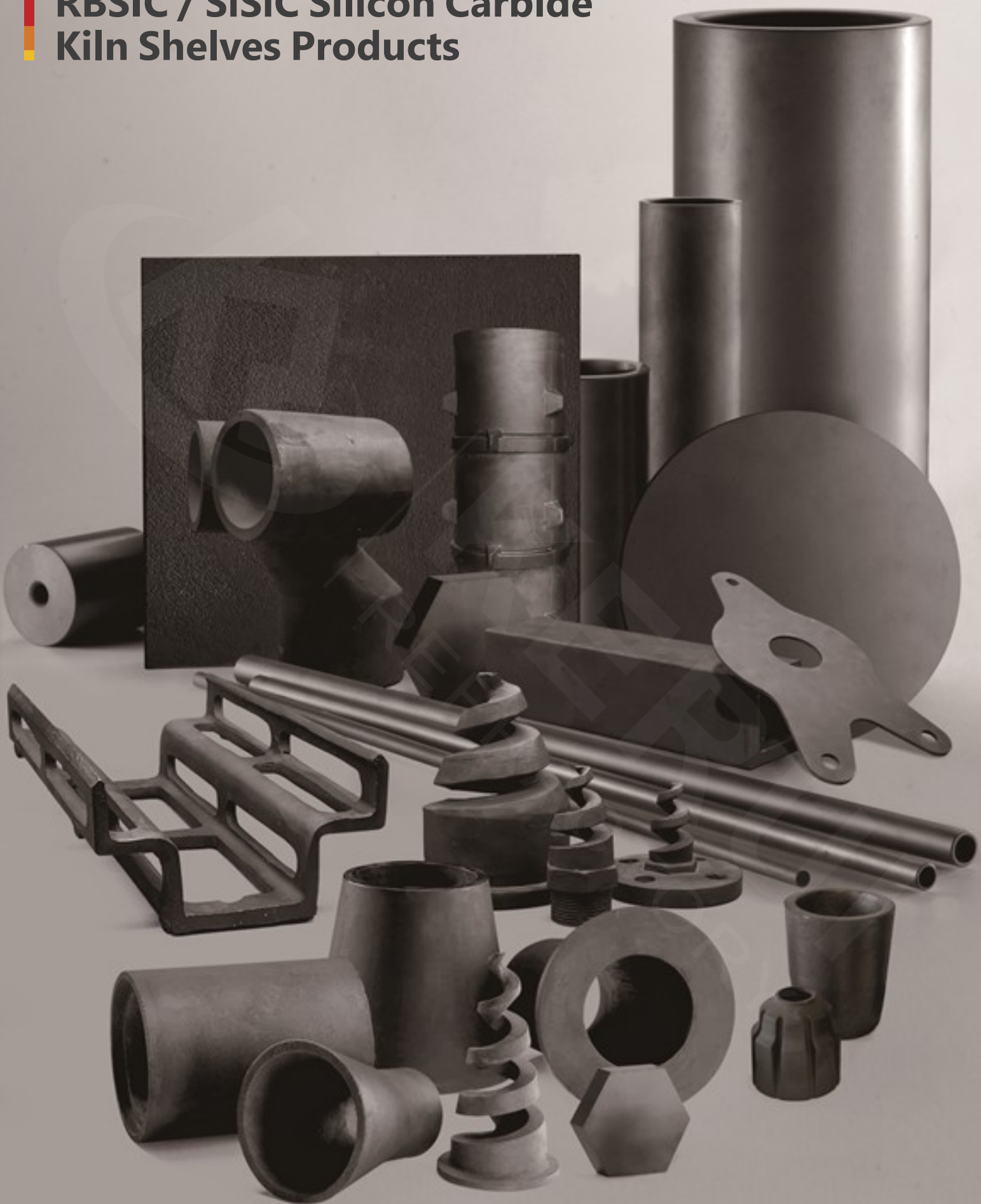

OBSiC Silicon Carbide Plates

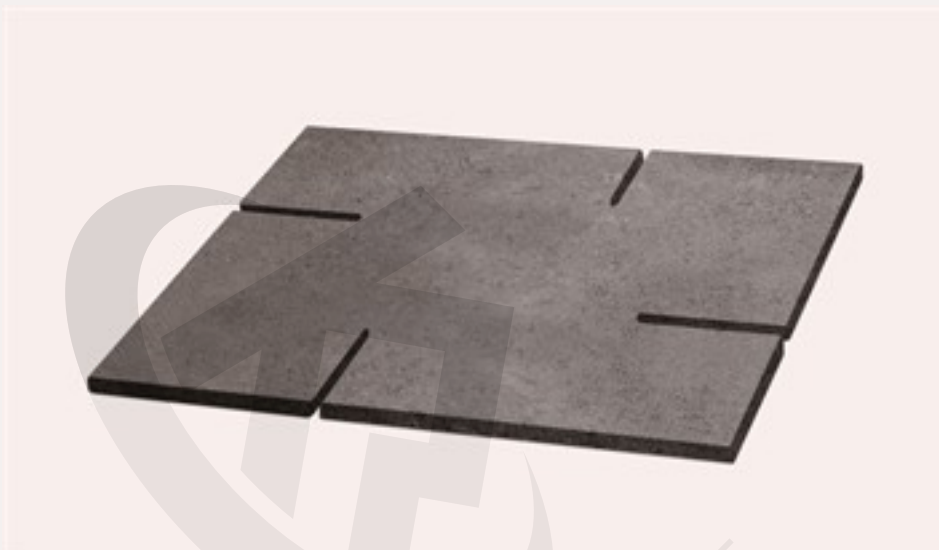

Save More Than
20% of Energy



Long Service
Life



High Thermal
Conductivity



Good Anti-
gasification

Application:

OBSiC silicon carbide plates have good thermal conductivity and heat resistance and are widely used in household ceramics, ceramic sanitary ware, microcrystalline glass, powder metallurgy, electronic ceramics, etc. It can be made of square plates, round plates, and various special-shaped plates.

Technical Data:

Item		Index
SIC Chemical Composition, %	≥	90
Max.Service Temp, °C		1500
Refractoriness, SK	≥	39
2kg/cm ² Refractoriness Under Load, kg/cm ²	≥	1750
Modulus of Rupture at Room Temp, kg/cm ²	≥	500
Modulus of Rupture at 1400°C, kg/cm ²	≥	100
Compressive Strength, %≥	≥	1300
Thermal Expansion at 1000°C, %		0.42 -0.48
Apparent Porosity, %		7-8
Bulk Density, g/cm ²		2.70 -2.75
Thermal Conductivity at 1000°C, kcal/m.hr. °C		13.5-14.5

The above functions and features can be designed according to the actual requirements of customers

Sizes Technical Data:

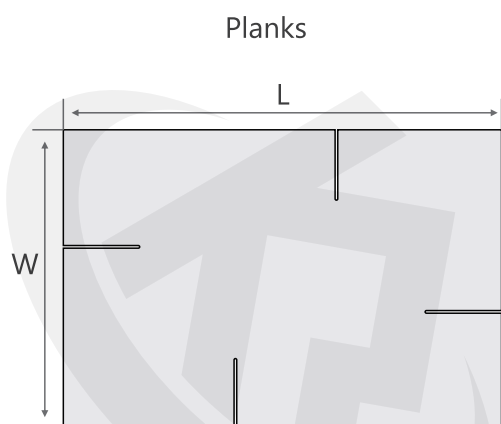

L x W	L x W	L x W	L x W	L x W
765x730	600x 550	520x490	460x440	400x 380
760x550	600x520	520x400	460x350	400x 350
760x520	600x500	500x500	460x320	400x 300
760x500	600x400	500x480	450x450	400x250
740x520	600x370	500x450	450x430	380x 380
732x 445	600*300	500x400	450x420	365x365
720*630	570x500	500x390	450x400	350x350
700x700	560x270	500x370	450x 380	350x 300
700x550	550x550	500x 300	450*350	340x 340
700x520	550x520	490x470	450x 340	340x320
700x500	550x 500	480x 480	450x300	340x310
700x450	550x480	480x 420	440x 440	330x330
700x400	550x450	480x400	430x420	320x320
660x600	550x430	480x 380	430x 340	310x310
650x400	550x400	480x 360	420x300	300x 300
640*600	550x370	480x 330	420x400	290x290
640x 500	550x300	480x280	420x380	250x250
610x610	530x530	470x 360	420x 340	240x240
600x600	520x500	470x 340	400x400	150x150

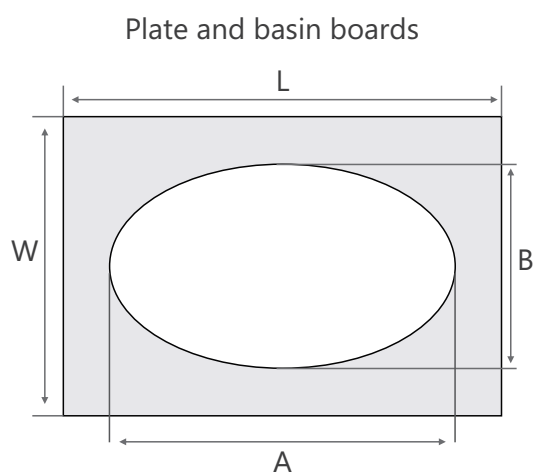

L x W	L x W	L x W	L x W
750x550	654x550	645x525	620x510
700x600	650x590	645x515	620x500
700x550	650x545	635x535	600x 520
670x555	650x520	630x515	600x510
660x535	645x545	625x497	570x520

Note: sizes A and B are also available.
Thickness of 15~20mm in addition to the user's requirements for the specification of production supply.

RBSiC / SiSiC Silicon Carbide Products



Minimal Thermal
Expansion



Strong Chemical
Resistance



High-temperature
Stability



Uniform Heat
Distribution

Application:

RBSiC / SiSiC silicon carbide products are made from high-purity, fine-grained silicon carbide materials. We offer a wide range of silicon carbide products, including shelves, batts, supports, beams, and tubes, which can be customized to meet the specific needs of our customers.

Technical Data:

Item		Index
Max Temperature of Application, °C		1380
Bulk Density, kg/m ³	>	3.02
Open Porosity, %	<	0.1
Bonding Strength, Mpa		250Mpa (20°C)
		280Mpa (1200°C)
Modulus of Elasticity, GPa		330GPa (20°C)
		300GPa (1200°C)
Thermal Conductivity, W/m.k		45 (1200°C)
Coefficient of Thermal Expansion, K ⁻¹ *10 ⁻⁶		4.5
Moh' s Hardness		9.15
Vickers Hardness HV, GPa		20
Acid Alkaline-proof		Excellent

RBSiC / SiSiC Silicon Carbide Products



SiSiC (RBSiC) Rollers

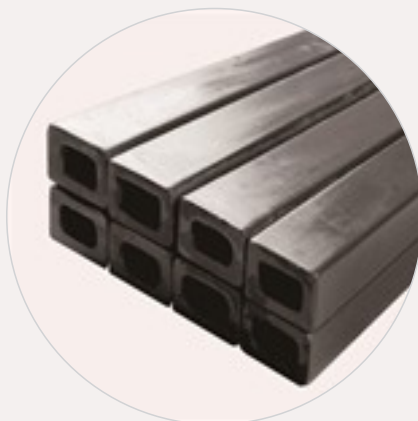

SiSiC BEAMS



SiSiC Crucible Sagger



SiSiC Radiation Pipe



Reaction Sintered Silicon
Carbide Cantilever



SiSiC Cooling Air Pipe



SiSiC (RBSiC) Burner Nozzles



Vortex Hollow Cone
Spray Nozzle



Spiral Spray Nozzle

Silicon Carbide Graphite Crucible

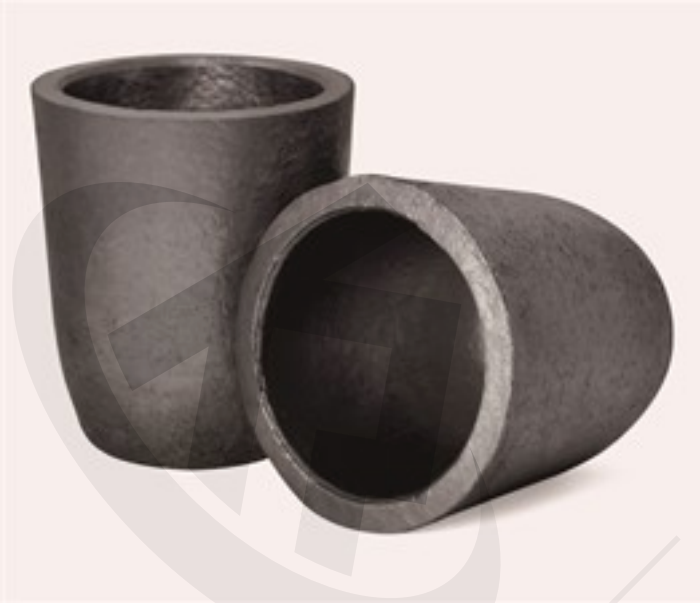

Good Thermal
Stability



Good Corrosion
Resistance



Good Thermal
Conductivity



Saving Energy

Application:

The material used for graphite crucible is made of high purity, high strength and high density graphite refractory material, which can be made into graphite crucible, graphite casting crucible and graphite oil tank through CNC processing.

Technical Data:

Item	I		II	
	Plasticity (S)	Isostatic pressure (D)	Plasticity (S)	Isostatic pressure (D)
Forming Method				
Carbon Content, %	≥ 38	45	38	45
Bulk Density, g/cm ³	≥ 1.7	1.85	1.7	1.85
Porosity, %	≥ 29	21	29	21
Normal Temperature Compressive Strength, MPa	≥ 20	25	20	25
Fire Resistance, °C	≥ 1500	1500	1400	1400

Model Technical Data:

Model	Upper Port Outside Diameter $\pm 2\%$	Thickness	Lower Bottom Outside Diameter $\pm 2\%$	Height $\pm 2\%$
1#	67	8 \pm 1.0	35	65
1.5#	78	10 \pm 1.0	60	80
2#	88	10 \pm 1.0	62	100
3#	100	12 \pm 1.0	75	115
4#	115	12 \pm 1.0	85	115
5#	122	13 \pm 1.0	85	138
6#	125	14 \pm 1.0	85	155
41#	215	19~ 21.5	150	290
45#	250	19~ 21.5	180	295
70#	285	19~ 21.5	215	245
80#	310	20~ 22.5	210	370
90#	320	21~ 23.5	230	385
100#	314	21~ 23.5	220	408
200#	400	23~ 25.5	290	475
260#	416	24~ 26.5	250	585
300#	452	26~ 29	310	580
360#	462	28~ 31	342	674
390#	530	28~ 31	410	560
400#	515	29~ 32	340	600
420#	515	29~ 32	330	673

Model Technical Data:

Model	Upper Port Outside Diameter $\pm 2\%$	Thickness	Lower Bottom Outside Diameter $\pm 2\%$	Height $\pm 2\%$
440#	620	29~ 32	340	500
450#	516	32~ 35	340	710
530#	580	31~ 34	330	635
560#	590	33~ 36	330	690
570#	620	33~ 36	335	570
580#	545	33~ 36	317	750
610#	607	34~ 38	350	630
680#	585	34~ 38	330	760
690#	600	34~ 38	330	805
700#	615	34~ 38	350	758
840#	700	35~ 39	470	675
950#	720	37~ 41	300	740
970#	720	34~ 38	470	730
1100#	715	35~ 39	478	846
1150#	855	42~ 46	340	677
1200#	780	36~ 40	450	752
1250#	725	36~ 40	470	905
1500#	784	37~ 41	450	890
1700#	778	40~ 44	442	1050
2500#	880	44~ 48	350	1150

Recrystallized Silicon Carbide (RSIC) Kiln Furniture



Reduced Energy Consumption



Reduced Weight and Energy Saving



High Strength Under High Temperature



Outstanding Shape Stability

Application:

Products from Starlight are made of high purity SiC raw material, after molding, sintered in vacuum induction furnace. The specific chemical composition, purity and ceramic structure fulfill all the condition for different application.

Technical Data:

Item	RSIC
Contents	SiC \geq 99%
Bulk Density, g.cm ⁻³	2.65-2.75
Apparent Porosity, %	< 15
Modulus of Ruture at 20°C, Mpa	90-100
Modulus of Rupture at 1200°C, Mpa	100-110
Hardness at 20°C, Kg/mm ²	1800-2000
Fracture Toughness at 20°C, Mpa*M ^{1/2}	1.8-2.0
Thermal Conductivity at 1200°C, W/m.k	35-36
Thermal Expansion at 20-1200°C, 1x10 ⁻⁶ */°C	4.6
Thermal Shock Resistance at 1200°C	Very good
Max.working Temperature	1650°C

Si₃N₄ bonded SiC (NSIC) Kiln Furniture

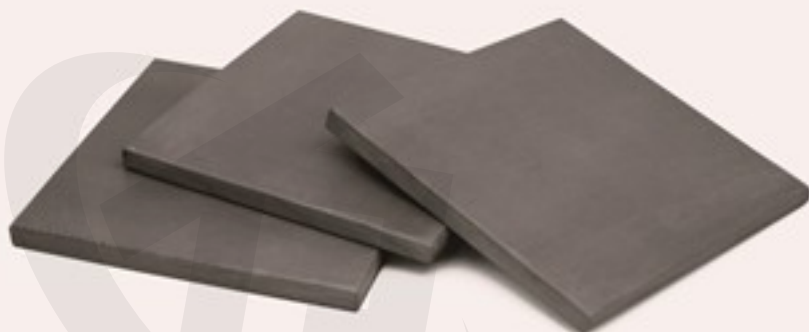

High Bending
Strength



Excellent Oxidation
Resistance



Excellent Wearing
Resistance



High Corrosion Resistance
Against Molten Metal

Application:

NSIC material are made of high pure SiC and Si powders, via Slip Casting or Compress Molding shaping process, Sintered and Nitried in high temperature furnaces. The NSiC products are mainly including the plate & batt, tube, burner nozzle, beam, aluminum cell and other special application parts.

Technical Data:

Item	NSIC
Contents	SiC≤75% Si ₃ N ₄ ≥25%
Bulk Density, g.cm ⁻³	2.75-2.85
Apparent Porosity, %	< 11
Modulus of Ruture at 20°C, Mpa	160-170
Modulus of Rupture at 1200°C, Mpa	170-180
Hardness at 20°C, Kg/mm ²	2500
Fracture Toughness at 20°C, Mpa*M ^{1/2}	4.0
Thermal Conductivity at 1200°C, W/m.k	20
Thermal Expansion at 20-1200°C, 1x10 ⁻⁶ */°C	4.7
Thermal Shock Resistance at 1200°C	Excellent
Max.working Temperature	1500°C



Reduced Energy
Consumption



Reduced Weight and
Energy Saving



High Strength Under
High Temperature



Outstanding Shape
Stability

Application:

High temperature equipment such as kilns will encounter high temperatures and strong chemical erosion. In harsh environments of high temperature and high corrosion, pressureless sintered silicon carbide ceramic protection tubes are usually used. They are resistant to physical and chemical damage at high temperatures.

Technical Data:

Item	SSIC
Volume Density, g/cm ³	≥3.13
Hardness, HRA	92-94
Indicated Porosity, %	< 0.2
Compressive Strength, Mpa	≥2200
Bending Strength, Mpa	≥400
Purity (SIC Percentage), %	≥99
Elastic Modulus, Gpa	400
Thermal Conductivity at 20°C, W/m.k	120-150
Maximum Temperature, °C	1650
Coefficient Of Heat Expansion, 1.10 ⁻⁶ m/k	4.0
Resistivity at 20°C, Ω.cm	5X10 ⁶

Cordierit-Mullite Kiln Shelves

Serving the Global High-temperature Industry



Cordierite-Mullite Kiln Shelves



High Temperature
Strength



Stronger Resistance
to Deformation



Excellent Thermal
Shock Resistance



Good Thermal
Conductivity

Application:

Cordierite-Mullite kiln furniture is a combination of cordierite, mullite and a glassy phase. It possesses excellent thermal shock resistance and is suitable for high temperature environments. It is the best refractory for use in kiln furniture and kiln construction where operating temperatures are under 1300°C.

Technical Data:

Item	Index
Mineralogy	Cordierite-Mullite
Al ₂ O ₃ , %	37
SiO ₂ , %	50
MgO, %	8.0
Bulk Density, g/cm ³	1.85
Apparent Porosity, %	28
M.O.R. @ 20°C, Mpa	15
M.O.R. @1250°C, Mpa	13
℄.T.E.@ 25°C-1000, 10 K	2.4
Specific Heat @20°C, Kj/Kg.K	1.0
Thermal Shock Resistance, ★	★★★★
Max Working Temperature, °C	1320

Cordierit-Mullite Plain Batts

Technical Data:

Item	Length	Width	Thickness
KR 2836	280	360	10-40
KR 2858	280	580	13-40
KR 3050	300	500	10-40
KR 3345	330	450	12-40
KR 3434	340	340	10-40
KR 3444	340	440	10-40
KR 3540	350	400	10-40
KR 3636	360	360	10-40
KR 3670	360	700	15-40
KR 3745	370	450	12-40
KR 3770	370	700	15-40
KR 3842	380	420	10-40
KR 3946	390	460	12-40
KR 4042	400	420	12-40
KR 4050	400	500	13-40
KR 4060	400	600	13-40
KR 4242	420	420	13-40
KR 4248	420	480	13-40
KR 4343	430	430	13-40
KR 4545	450	450	13-40
KR 4550	450	500	13-40
KR 4565	450	650	15-40
KR 4648	460	480	15-40
KR 4848	480	480	15-40
KR 4870	480	700	15-40
KR 5052	500	520	15-40
KR 5057	500	570	15-40
KR 5065	500	650	15-40

Cordierit-Mullite Extruded Batts

Shape Cross Section

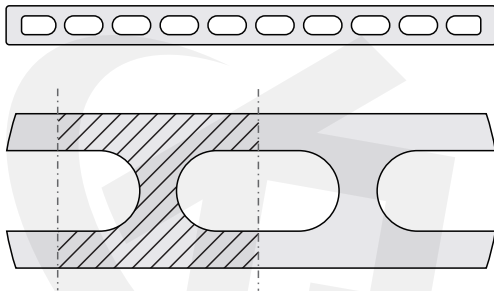

Supported by SiC Beams

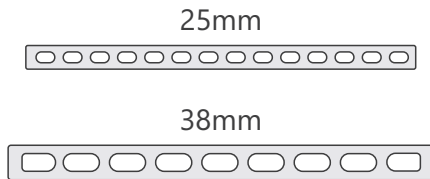

Drilling Holes

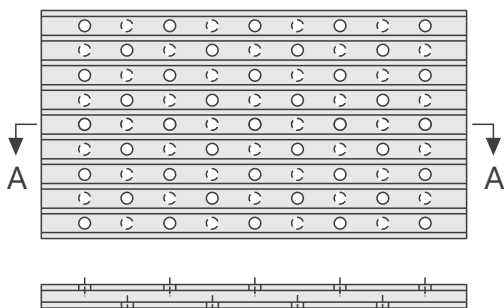

With the same weight, the extruded batt provides many times more carrying capacity than the solid batt

Thickness of Extruded Batts	25mm	38mm	46mm
Corresponding Thickness of Solid Batts	16mm	21mm	23mm
Carrying Capacity of Extruded Batts	3 times of solid batt	5 times of solid batt	8 times of solid batt

Thickness	Width	Available Length	Unit Weight		Maximum Load @1200°C, kg/500mm
			Kg/m	Kg/m ²	
25mm	270	900	8.5	31.5	24
	310	900	9.2	29.7	28
	330	900	11.9	36.1	31
	380	900	11.6	30.5	34
	396	900	12.9	32.6	36
	410	900	14.9	36.3	38
	440	900	13.1	29.8	38
	450	900	13.5	30.0	40
	475	900	15.2	32.0	43
	500	900	16.4	32.8	45
	525	900	17.9	34.1	47
	25mm	360	900	16.6	46.0
380		900	17.9	47.1	135
400		900	18.5	46.3	140
415		900	19.8	47.6	146
420		920	20.0	47.6	150
440		920	21.0	47.7	157
450		920	21.4	47.6	160
460		920	22.2	48.2	164
480		940	24.2	50.4	170
485		940	25.0	51.5	172
495		940	25.2	50.9	174
500		940	23.3	46.6	175
505		940	23.7	46.9	180
510		960	23.5	46.1	180
520		960	24.0	46.2	180
525		960	25.5	48.5	181
545		960	25.8	47.3	192
550		980	25.2	45.8	195
590		980	26.9	45.6	205
600		980	27.1	45.2	207
610		980	27.5	45.1	210
615		980	28.8	46.8	216
632		1000	30.8	48.8	221
660		1000	31.4	47.5	230
675	1000	32.4	48.0	237	
680	1000	32.5	47.8	240	
750	1000	32.4	43.2	260	

Cordierit-Mullite Grooved Batts

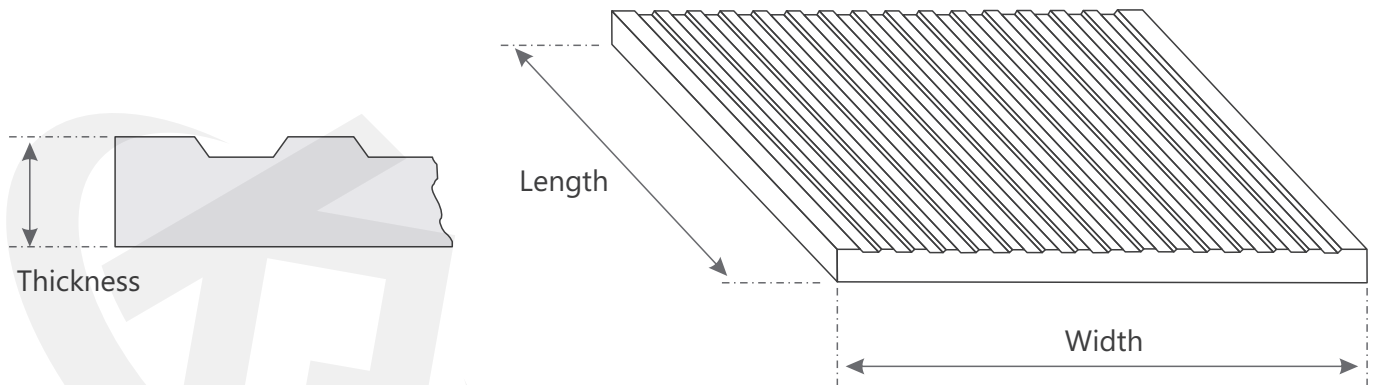

Item	Length	Width	Thickness
KR 3636	360	360	13-15
KR 3750	370	500	13-15
KR 3838	380	380	13-15
KR 3842	380	420	13-15
KR 4040	400	400	13-15
KR 4042	400	420	13-15
KR 4045	400	450	13-15
KR 4242	420	420	13-15
KR 4245	420	450	13-15
KR 4348	430	480	13-15
KR 4545	450	450	13-15
KR 4548	450	480	13-15
KR 4550	450	500	13-15
KR 4850	480	500	13-15
KR 5050	500	500	15-18
KR 5060	500	600	15-18

Cordierit-Mullite Common/Cubic Supports

Common Support

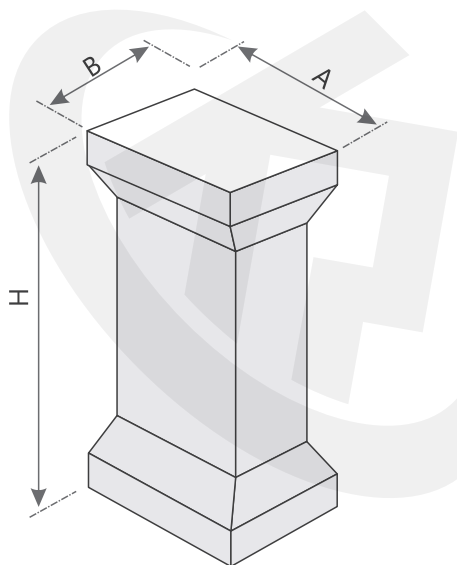

Code:SS

Item	A	B	H	Weights, kg/m
SS 456	50	40	60	0.20
SS 458	50	40	80	0.26
SS 468	60	40	80	0.31
SS 469	60	50	90	0.34
SS 4610	60	45	100	0.41
SS 4612	60	45	120	0.47
SS 4613	60	45	130	0.50
SS 4614	60	45	145	0.55
SS 4615	60	45	150	0.57
SS 5616	60	50	160	0.65
SS 5617	60	50	170	0.65
SS 5618	60	50	180	0.78
SS 5620	60	50	200	0.85
SS 5622	60	50	220	1.04
SS 5624	60	50	240	1.12

Cubic Support

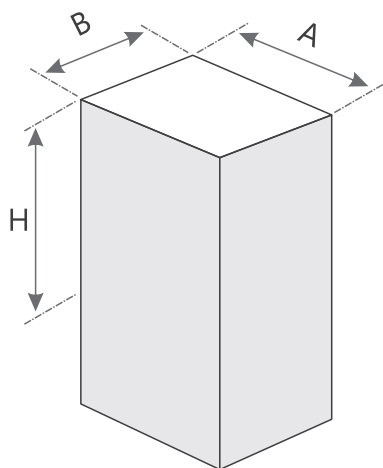

Code:CS

Item	A	B	H	Weights, kg/m
CS 357	30	50	70	0.21
CS 456	40	50	60	0.24
CS 460	40	60	100	0.48
CS 468	40	60	80	0.38
CS 567	50	60	70	0.42
CS 680	60	80	100	0.96
CS 5712	50	70	120	0.84
CS 7712	78	78	120	1.46
CS 7812	70	80	120	1.34

Cordierit-Mullite Extruded Supports

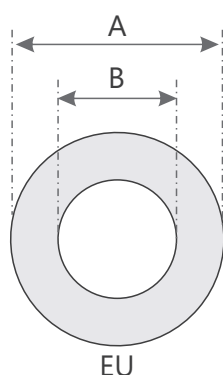
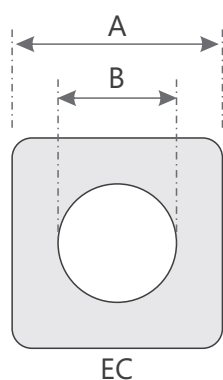
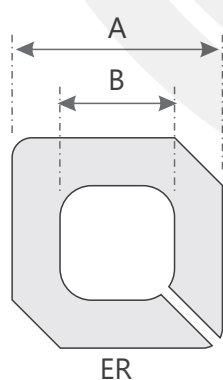
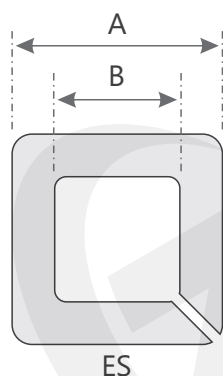

Item	SizeA	SizeB	Max.Length	Weights kg/m
ES 51/31	51	31	1000	3.2
ES 65/40	65	40	1000	5.3
ES 80/45	80	45	1000	8.8
ES 95/50	95	50	1200	13.1
ES 102/38	102	38	1200	17.9
ES 102/52	102	52	1200	15.4
ES 105/59	105	59	1200	15.1
ES 125/52	125	52	1200	25.8
ES 125/55	125	55	1200	25.2
ES 137/73	137	73	1200	26.9
ES 203/102	203	102	1200	6.16
EC 28/12	28	12	800	1.3
EC 37/24	37	24	800	1.8
EC 40/16	40	16	800	2.8
EC 51/23	51	23	800	4.4
ER 70/40	70	40	1000	6.6
ER 80/50	80	50	1000	7.8
ER 90/60	90	60	1000	9.0
ER 92/50	92	50	1000	11.9
EU 50/25	50	25	800	3.0
EU 55/25	55	25	800	3.8
EU 60/35	60	35	800	3.7
EU 64/35	64	35	800	4.5
EU 70/40	70	40	800	5.2
EU 75/45	75	45	1000	5.7
EU 76/38	76	38	1000	6.8
EU 76/50	76	50	1000	5.1
EU 80/50	80	50	1000	6.1
EU 102/51	102	51	1000	12.3
EU 102/60	102	60	1000	10.7
EU 102/65	102	65	1000	9.7
EU 112/62	112	62	1000	13.7
EU 120/75	120	75	1000	13.8
EU 140/100	140	100	1000	15.1

Cordierit-Mullite Slotted Supports/Splicers

Slotted Supports

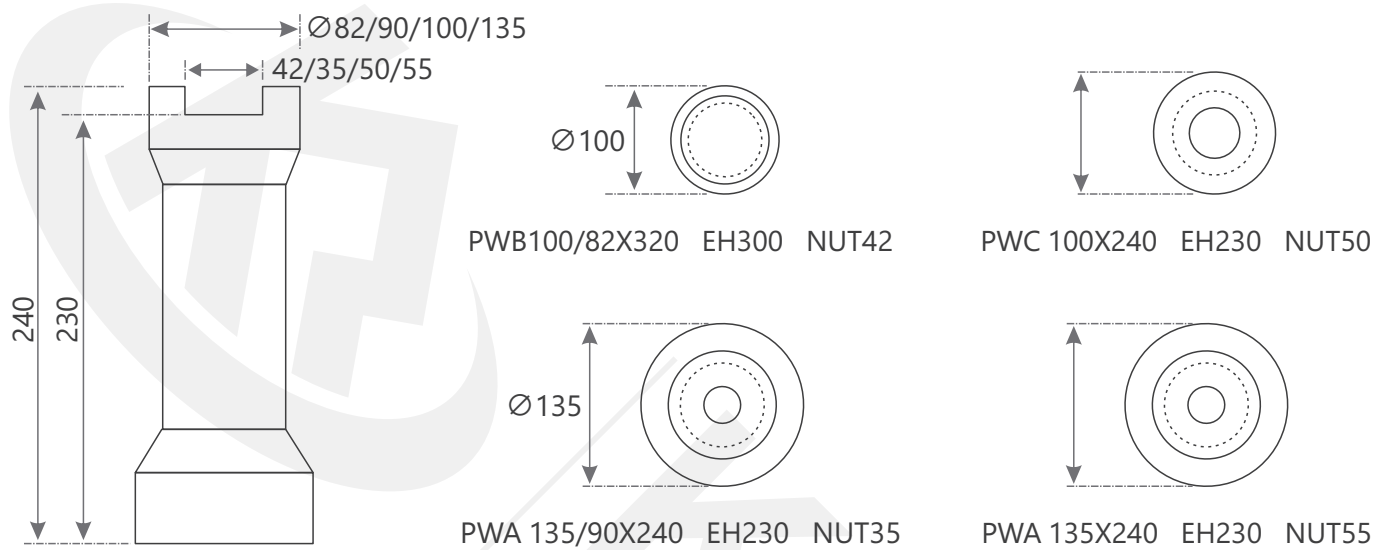

Cordierit-Mullite Splicers

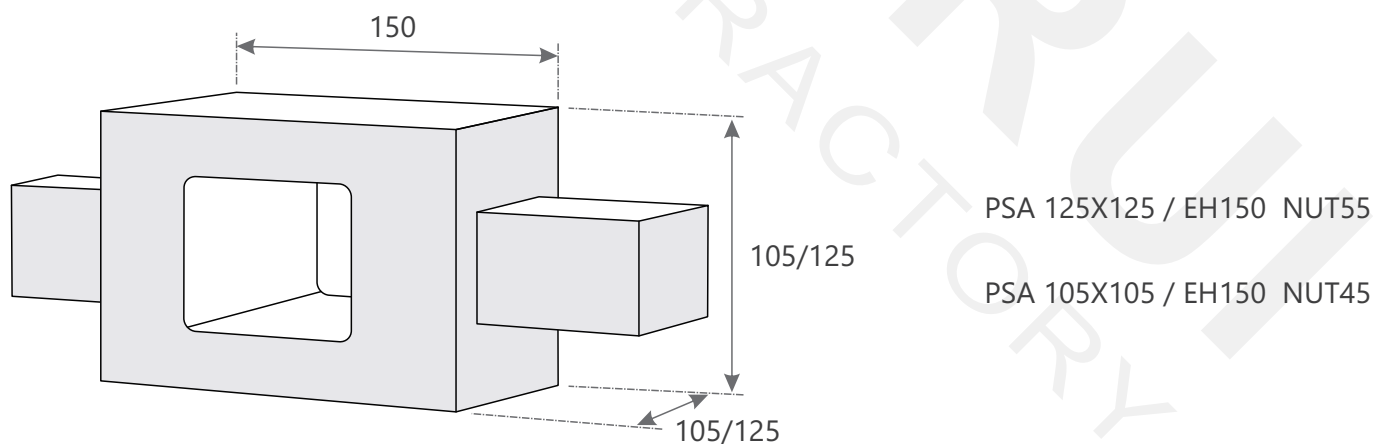



☎ Email: info@krefractory.com

✉ Tel: 0086 153 7871 8880

🌐 Website: krefractory.com



Whatsapp